

The objective of this homework is to test your understanding of the content of Module 6. Due date of the homework is: **Sunday, March 29th, 2020, @ 11.59PM.**

1. Using the Routh-Array method we discussed in Module 6 (in addition to the two special cases we discussed), determine whether the following system has any poles in the right half plane. Determine the number of these RHP poles.

$$H(s) = \frac{1}{s^4 + s^3 + 12s^2 + 12s + 36}.$$

Solutions: First, we construct the array:

$$\begin{array}{c|ccc} s^4 & 1 & 12 & 36 \\ s^3 & 1 & 12 & 0 \\ s^2 & 0 \rightarrow \approx \epsilon & 36 & \\ s^1 & \frac{12 \cdot \epsilon - 36}{\epsilon} & & \\ s^0 & 36 & & \end{array}$$

For $\epsilon > 0$, $\frac{12 \cdot \epsilon - 36}{\epsilon}$ is negative. Therefore, we have two sign changes in the TF which means we have two poles in the RHP.

2. For this CLTF,

$$H(s) = \frac{1}{s^3 + 7s^2 + 11s + (5 + K)},$$

determine the range of K (which could include negative numbers, for this problem only) such that the system has no poles in the RHP. Consider all the cases.

Solutions: First, we construct the Routh array:

$$\begin{array}{c} s^3 \\ s^2 \\ s^1 \\ s^0 \end{array} \left\| \begin{array}{cc} 1 & 11 \\ 7 & 5 + K \\ \frac{72 - K}{7} & \\ 5 + K & \end{array} \right.$$

Since it's required to have no poles in the RHP, we need no sign changes (Case 1) or zero entries (Case 2).

Case 1: assuming that we want only positive signs in the first column of the array, we would need $72 - K > 0$ **AND** $5 + K > 0$, or:

$$-5 < K < 72.$$

Case 2: assuming that we are permitting some entries to be zero, we can have $K = 72$. In this case, we obtain an updated array:

$$\begin{array}{c} s^3 \\ s^2 \\ s^1 \\ s^0 \end{array} \left\| \begin{array}{cc} 1 & 11 \\ 7 & 77 \\ 14 & \\ 77 & \end{array} \right.$$

Here, we had to replace this row with an auxiliary polynomial

In this case, we have no sign changes, hence $K = 72$ is an acceptable solution. Similarly, we select $K = 5$, and reconstruct the Routh array again. For $K = 5$, we also obtain no sign changes, therefore the range for acceptable values for K is:

$$\boxed{-5 \leq K \leq 72.}$$

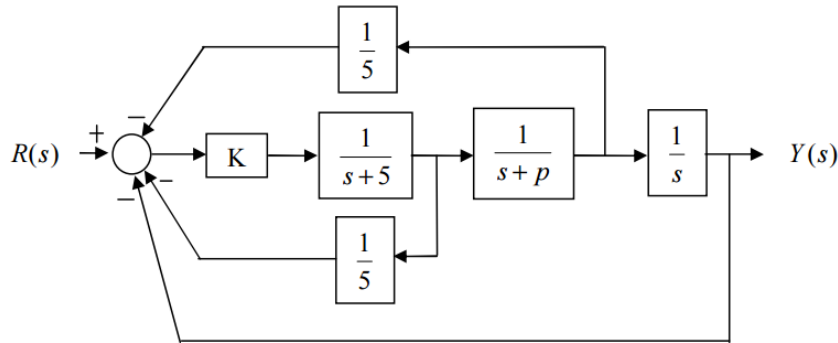

Figure 1: Spark ignition system — a block diagram representation.

3. The system shown in Figure 1 is a typical block diagram representation depicting a simplified spark ignition system of an engine. Two parameters of this system are the gain K and performance parameter p . The performance parameter can take two values: $p_1 = 0$ and $p_2 = 2$. The objective of this problem is to design a gain K to stabilize the initially unstable system. Answer the following questions.

- (a) Find the overall closed loop transfer function $\frac{Y(s)}{R(s)}$ in terms of p and K . You should end up with a typical TF with polynomials on the denominator and numerator. Your CLTF should be third order TF. Make sure that your answer is correct before you move to the next question.
- (b) Obtain a value (or values) for K that would make the CLTF stable for the two given values of p , **simultaneously**. In other words, your design should stabilize the system whether $p = 0$ or $p = 2$.

Hint: you should end up with two Routh-Arrays in terms of p and K .

Solutions:

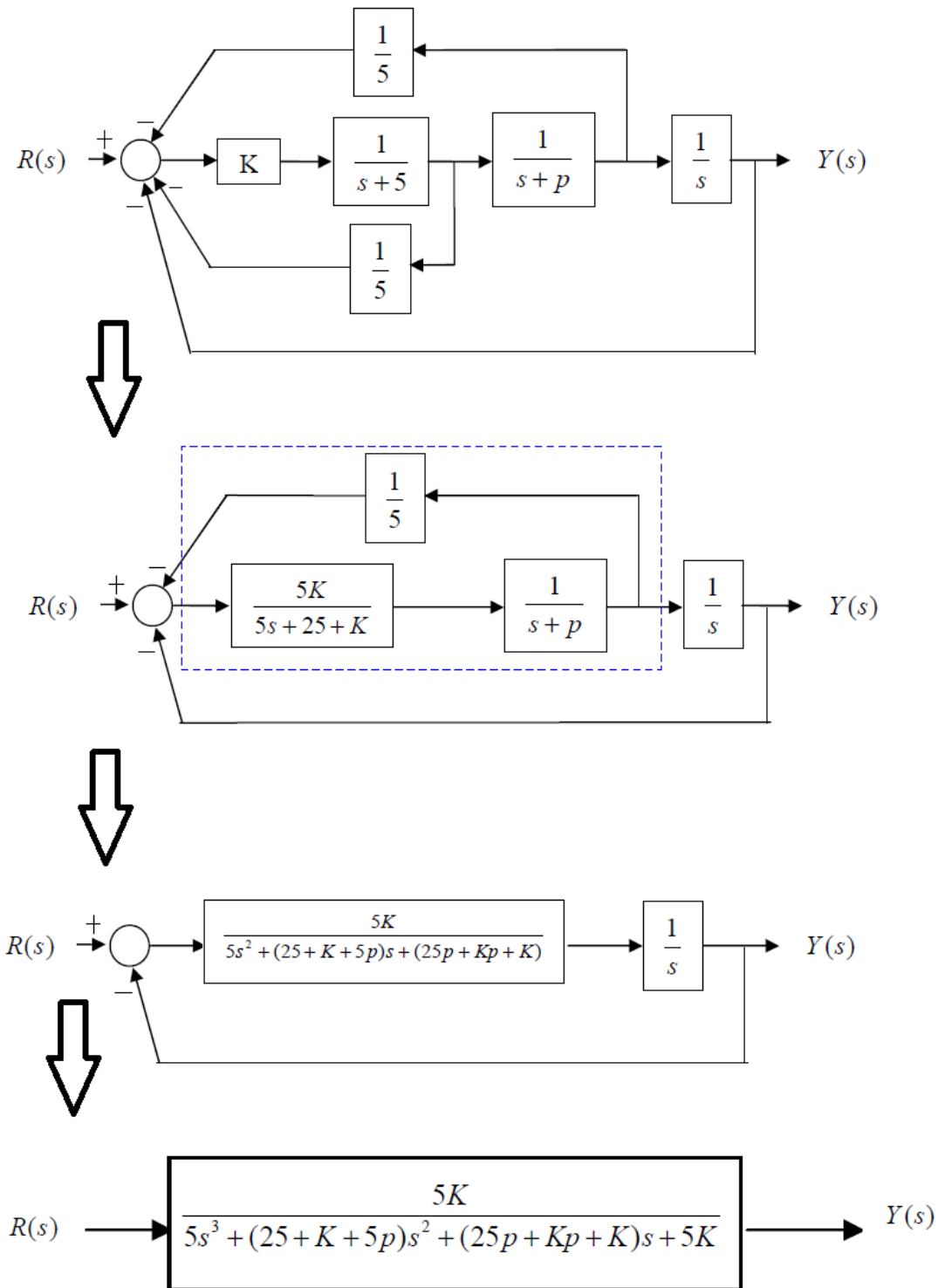

- (a)
- (b) Since we have two different values for p , we need to construct two Routh arrays corresponding to the two values.

Case 1: For $p = 0$, the Routh array is as follows:

$$\begin{array}{c|cc} s^3 & 5 & K \\ s^2 & 25 + K & 5K \\ s^1 & \frac{K^2}{25 + K} & \\ s^0 & 5K & \end{array}$$

Since our objective is to obtain a stable CLTF for $p = 0$, we want to make sure that there are no sign changes in the first column. Hence, we need:

$$25 + K > 0, \quad \frac{K^2}{25 + K} > 0, \quad 5K > 0.$$

The solution for the above inequalities is $K > 0$. Note that we want the intersection of the three inequalities to hold, not one of them. This is satisfied via $K > 0$.

Case 2: For $p = 2$, the Routh array is as follows:

$$\begin{array}{c|ccc} s^3 & 5 & & 50 + 3K \\ s^2 & 35 + K & & 5K \\ s^1 & \frac{3K^2 + 80K + 1750}{35 + K} & & \\ s^0 & 5K & & \end{array}$$

Since our objective is to obtain a stable CLTF for $p = 2$, we want to make sure that there are no sign changes in the first column. Hence, we need:

$$35 + K > 0, \quad \frac{3K^2 + 80K + 1750}{35 + K} > 0, \quad 5K > 0.$$

The solution for the above inequalities is also $K > 0$. Similar to Case 1, we want the intersection of the three inequalities to hold, not one of them. This is satisfied via $K > 0$. You can easily check that by finding the sign of $3K^2 + 80K + 1750$.

Overall Solution: Combining the two conditions from Cases 1 and 2, the solution is:

$$\boxed{K > 0.}$$

4. For the unity feedback system in shown in Figure 2, the open-loop TF is given as follows:

$$G(s) = \frac{K(s + \alpha)}{s(s + \beta)},$$

where K, α and β are parameters that I want you to design. The design objectives are:

- Steady-state error $\frac{1}{10}$;
- Closed-loop poles are: $p_{1,2} = -1 \pm j$.

Find α, β and K such that the above design objectives are satisfied.

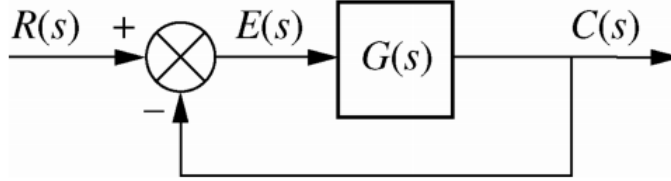

Figure 2: Unity feedback system.

Solutions: First, note that this is a Type 1 system as s^1 exists in the denominator. For Type 1 systems with ramp input, the steady-state error is equal to (class derivation and Module 06):

$$e_{ramp}(\infty) = \lim_{s \rightarrow 0} \frac{1}{sG(s)}.$$

According to the problem given, the steady state error is $1/10$, hence:

$$e_{ramp}(\infty) = \lim_{s \rightarrow 0} \frac{1}{sG(s)} = \frac{1}{10} = \frac{1}{s \frac{K(s + \alpha)}{s(s + \beta)}} = \frac{\beta}{\alpha K}.$$

Hence,

$$10 = \frac{\alpha K}{\beta} \Rightarrow \boxed{10\beta = \alpha K}.$$

Also, the problem given states that the poles of the CLTF are $-1 \pm j$. We can easily obtain the CLTF in terms of α, β, K :

$$\frac{C(s)}{R(s)} = \frac{K(s + \alpha)}{s^2 + (\beta + K)s + K\alpha}.$$

The poles of the CLTF are:

$$p_{1,2} = \frac{-\beta - K \pm \sqrt{\beta^2 + K^2 + 2\beta K - 4K\alpha}}{2}.$$

Since the real term in the poles is equal to -1 , we have:

$$\frac{-\beta - K}{2} = -1 \Rightarrow \boxed{\beta = 2 - K}.$$

Furthermore, the complex part of the poles is equal to 1 , hence we need the term under the square-root ($\beta^2 + K^2 + 2\beta K - 4K\alpha$) to be equal to -4 , since it will be square-rooted and then divided by two. Plugging in the boxed equations above (i.e., $\beta = 2 - K, 10\beta = \alpha K$), we obtain:

$$\boxed{K = \frac{72}{40} = 1.8 \Rightarrow \beta = 2 - K = 0.2, \Rightarrow \alpha = \frac{10\beta}{K} = 1.111.}$$

Sanity check: plugging in these values for K, β , and α , we obtain the required steady-state error as well as the desired CLTF poles.